

Brandon Valley School District  
District Learning Plan  
March 23-27, 2020

Grade 5 Math



## Brandon Valley School District Distance Learning Plan

LESSON/UNIT: Chapter 12 Geometry

SUBJECT/GRADE: Math/5th

DATES: March 23-27, 2020



<p>What do students need to do?  <u><a href="#">PART ONE link to BV instructional video for March 23-27, 2020</a></u>   <u><a href="#">PART Two link to BV instructional video for March 23-27, 2020</a></u></p>	<p><b>Monday (3/23):</b> Review math textbook pages 935-936. Work independently on pages 937-940 for practice.  <b>Tuesday (3/24):</b> Review math textbook pages 941-942. Work independently on pages 943-944 . Complete homework pages 945-946, 1-7 to be assessed.  <b>Wednesday (3/25):</b> Review math textbook pages 949-950. Work independently on pages 951-954 for practice.  <b>Thursday (3/26):</b> Review math textbook pages 955-956. Work independently on page 957-958 for practice. Complete homework pages 959-960, 1-8 to be assessed.  <b>Friday (3/27):</b> Review math textbook pages 961-962. Work independently on page 963-964 for practice. Complete homework pages 965-966 , 1-10 to be assessed</p>
<p>What do students need to bring back to school?</p>	<p>Math text book with completed homework pages for chapter 12: Pages 943-944, 959-960, 965-966</p>
<p>What standards do the lessons cover?</p>	<p>Measurement and Data 5.MD  A. Convert like measurement units within a given measurement system.  1. Convert customary and metric measurement units within a given measurement system (e.g., convert 5 cm to 0.05 m). Use these conversions in solving multi-step, real world problems involving distances, intervals of time, liquid volumes, masses of objects, and money (including problems involving simple fractions or decimals). For example, 3.6 liters and 4.1 liters can be combined as 7.7 liters or 7700 milliliters.  B. Represent and interpret data.  2. Make a line plot to display a data set. a. Use operations on fractions of a unit (<math>\frac{1}{2}</math>, <math>\frac{1}{4}</math>, <math>\frac{1}{8}</math>) for this grade to solve problems involving information presented in line plots. b. Use information from a line plot representing an unequal situation and redistribute whole or fractional parts to create an equal distribution. For example, given different measurements of liquid in identical beakers, find the amount of liquid each beaker would contain if the total amount in all the beakers were redistributed equally  C. Geometric measurement: understand concepts of volume and relate volume to multiplication and to addition.  3. Recognize volume as an attribute of solid figures and understand concepts of volume measurement. a. A cube with side length 1 unit, called a “unit cube,” is said to have “one cubic unit” of volume, and can be used to measure volume. b. A solid figure which can be packed without gaps or overlaps using n unit cubes is said to have a volume of n cubic units.  4. Measure volumes by counting unit cubes, using cubic cm, cubic in, cubic ft, and improvised units.</p>
<p>What materials do students need? What extra resources can students use?</p>	<p>Need -Math Textbook  Extra -You Tube Videos  Day 1: <a href="https://www.youtube.com/watch?v=0Brhus7jiw4">https://www.youtube.com/watch?v=0Brhus7jiw4</a>  Day 2: <a href="https://www.youtube.com/watch?v=-auMordjl4k">https://www.youtube.com/watch?v=-auMordjl4k</a>  Day 3: <a href="https://www.youtube.com/watch?v=u1nWl2b0fT4">https://www.youtube.com/watch?v=u1nWl2b0fT4</a>  Day 4: <a href="https://www.youtube.com/watch?v=BAa0N9vvD0s">https://www.youtube.com/watch?v=BAa0N9vvD0s</a>  Day 5: <a href="https://www.youtube.com/watch?v=slQkp4Um36Q">https://www.youtube.com/watch?v=slQkp4Um36Q</a></p>

<p>What can students do if they finish early?</p>	<p>1.- State testing practice site- <a href="https://login10.cloud1.tds.airast.org/student/V388/Pages/LoginShell.aspx?c=SouthDakota_PT">https://login10.cloud1.tds.airast.org/student/V388/Pages/LoginShell.aspx?c=SouthDakota_PT</a></p> <p>2. ALEKS-- <a href="https://www.aleks.com/">https://www.aleks.com/</a></p> <p>3. Practice your math facts- <a href="https://www.factmonster.com/math/flashcards">https://www.factmonster.com/math/flashcards</a></p>
<p>Who can we contact if we have questions?</p>	<p><b>Brandon Valley Intermediate School</b></p> <p><b>Principal-</b> Mr. Skibsted- <a href="mailto:Nick.Skibsted@k12.sd.us">Nick.Skibsted@k12.sd.us</a></p> <p><b>Assistant Principal-</b> Mr. Pearson- <a href="mailto:Rick.Pearson@k12.sd.us">Rick.Pearson@k12.sd.us</a></p> <p><b>Math Teachers:</b></p> <p>Mr. Mashlan- <a href="mailto:Justin.Mashlan@k12.sd.us">Justin.Mashlan@k12.sd.us</a> (blue team)</p> <p>Mr. Carroll- <a href="mailto:Scott.Carroll@k12.sd.us">Scott.Carroll@k12.sd.us</a> (red team)</p> <p>Mr. Peters- <a href="mailto:Jon.Peters@k12.sd.us">Jon.Peters@k12.sd.us</a> (white team)</p> <p>Mr. Wiese- <a href="mailto:Alex.Wiese@k12.sd.us">Alex.Wiese@k12.sd.us</a> (silver team)</p>
<p><b>Notes:</b></p>	

***Instructional materials are posted below (if applicable)***

---

*Brandon Valley School District*

Name .....

# Lesson 7 Three-Dimensional Figures

**ESSENTIAL QUESTION ?**  
How does geometry help me solve problems in everyday life?

A **three-dimensional figure** has length, width, and height.

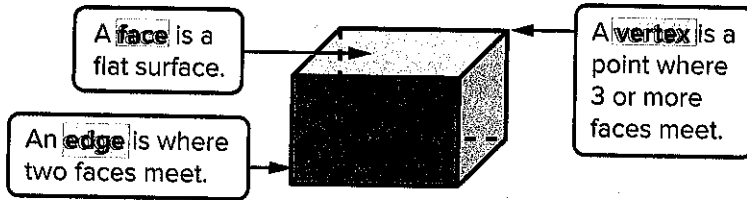

**Math in My World**



Describe the faces, edges, and vertices of the figure outlined on the luggage bag. Then identify the shape of the figure.

**faces** The figure has \_\_\_\_\_ faces. Each face appears to be a rectangle.

**edges** There are \_\_\_\_\_ edges. The opposite edges are parallel and congruent.

**vertices** The figure has \_\_\_\_\_ vertices.

Prisms are three-dimensional figures. A **prism** has at least three faces that are rectangles. The top and bottom faces, called the **bases**, are congruent parallel polygons.

The figure above is a rectangular prism. In a **rectangular prism**, the bases are congruent rectangles. A rectangular prism has six rectangular faces, twelve edges, and eight vertices.

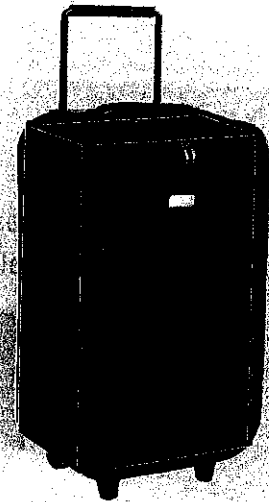

# Key Concept Prisms

**Rectangular Prism**

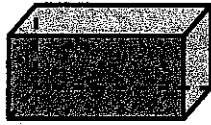

A rectangular prism has six rectangular faces, twelve edges, and eight vertices.

**Triangular Prism**



A triangular prism has triangular bases. It has five faces, nine edges, and six vertices.

**Cube**

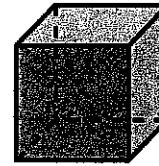

A cube has six square faces, twelve edges, and eight vertices. A cube is also a square prism.

## Guided Practice

1. Describe the faces, edges, and vertices of the three-dimensional figure. Then identify it.

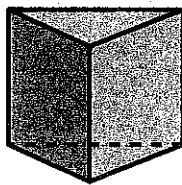

**faces** This figure has \_\_\_\_\_ faces. The \_\_\_\_\_ bases are congruent and parallel. The other faces are \_\_\_\_\_.

**edges** There are \_\_\_\_\_ edges. The edges that form the vertical sides of the rectangles are parallel and \_\_\_\_\_.

**vertices** This figure has \_\_\_\_\_ vertices.

The figure is a \_\_\_\_\_.

### Talk MATH

Describe the differences between a triangular prism and a rectangular prism.

Name \_\_\_\_\_

# Independent Practice

Describe the faces, edges, and vertices of each three-dimensional figure. Then identify it.

2.

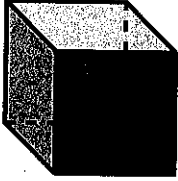

---

---

---

3.

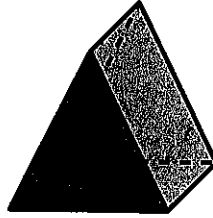

---

---

---

4.

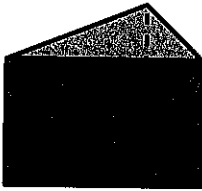

---

---

---

5.



---

---

---

6.



---

---

---

7.

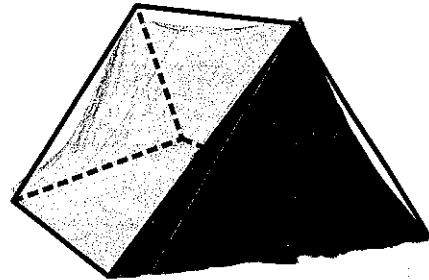

---

---

---



## Problem Solving

8. **Processes & Practices**



**Identify Structure** The Aon Center in

Chicago is in the shape of a rectangular prism. Circle the two-dimensional figures that make up the faces of the prism.

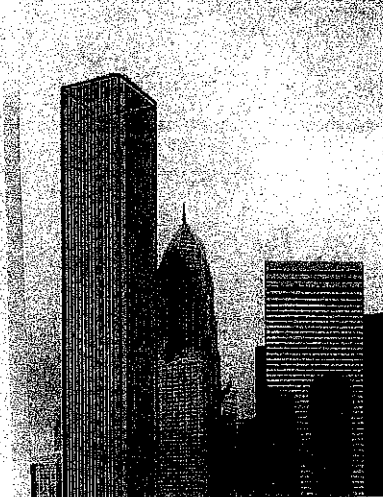
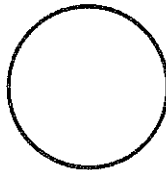
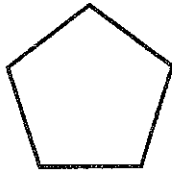
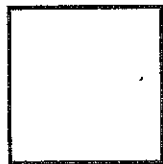

9. Describe the number of vertices and edges in an unopened cereal box. Identify the shape of the box.

\_\_\_\_\_

## Brain Builders

10. **Processes & Practices**



**Model Math** What figure is formed if only

the height of a cube is increased? Draw the figure to support your answer.

\_\_\_\_\_

\_\_\_\_\_

\_\_\_\_\_

11.



**Building on the Essential Question** How are rectangular prisms, triangular prisms, and cubes different? How are they the same?

\_\_\_\_\_

\_\_\_\_\_

Name \_\_\_\_\_

# Homework

## Lesson 7

### Three-Dimensional Figures

## Homework Helper



Need help? [connectED.mcgraw-hill.com](http://connectED.mcgraw-hill.com)

**Describe the faces, edges, and vertices of the ramp.  
Then identify the shape of the ramp.**

**faces** This figure has 5 faces.  
The triangular bases are congruent and parallel. The other faces are rectangles.

**edges** There are 9 edges. The edges that form the horizontal sides of the rectangles are parallel and congruent.

**vertices** This figure has 6 vertices.

The ramp is a triangular prism.

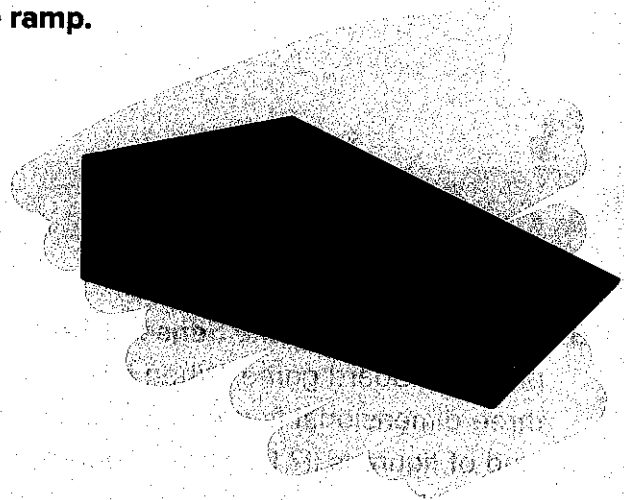

## Practice

**Describe the faces, edges, and vertices of each three-dimensional figure. Then identify it.**

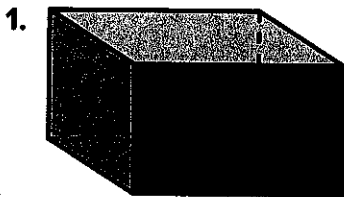

---

---

---

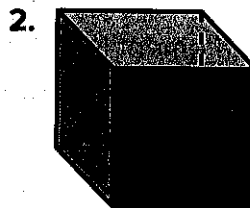

---

---

---





## Problem Solving

3. Rhett made a simple drawing of his house. It is a three-dimensional figure with four faces that are rectangular and two that are square. What kind of figure is it?
- .....

4. A toy box has 6 faces that are squares. There are 12 edges and 8 vertices. Identify the shape of the toy box.
- .....



## Brain Builders

### 5. Processes & Practices



**Make Sense of Problems** Gabriel is playing a board game. When it is his turn, he tosses a three-dimensional figure that has 6 square faces. What kind of figure is it? How many edges and vertices does it have? Draw the figure to support your answer.

.....

## Vocabulary Check



Fill in the blank with the correct term or number to complete the sentence.

6. A vertex is a point where \_\_\_\_\_ or more edges meet.

7. **Test Practice** Which statement is true about the three-dimensional figure that most closely represents the slice of pie?

- (A) The figure has 4 vertices.
- (B) The figure has 6 vertices.
- (C) The figure has 10 edges.
- (D) The figure has 12 edges.

Easy as pie



Name \_\_\_\_\_

## Lesson 6

# Hands On



## Build Three-Dimensional Figures

**ESSENTIAL QUESTION** ?  
How does geometry help me solve problems in everyday life?

A **three-dimensional figure** has length, width, and height. A **net** is a two-dimensional pattern of a three-dimensional figure. You can use a net to build a three-dimensional figure.

A **cube** is a three-dimensional figure with six faces that are congruent squares. **Congruent figures** have the same size and shape.

A **rectangular prism** is a three-dimensional figure with six rectangular faces. Opposite faces are parallel and congruent.

A **face** is a flat surface.

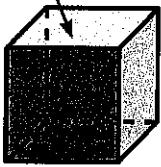

Cube



Rectangular Prism

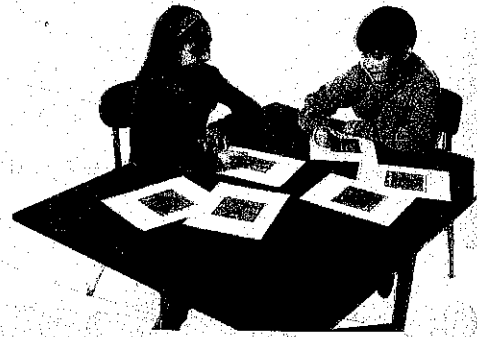

## Build It



1

Copy the net shown onto grid paper.

2

Cut out the net. Fold along the lines to form a three-dimensional figure. What figure did you form?

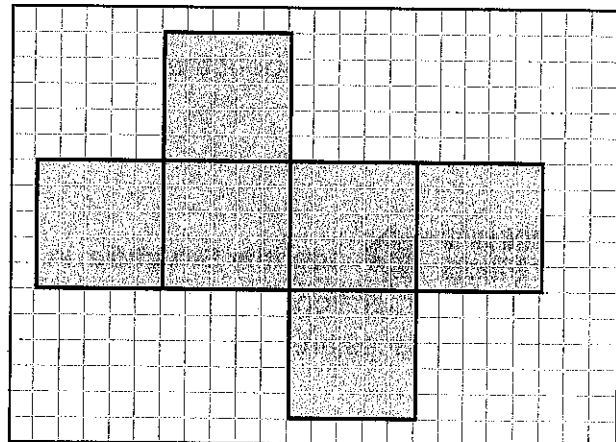

## Try It

1 Copy the net shown onto grid paper.

2 Cut out the net. Fold along the lines to form a three-dimensional figure. What figure did you form?

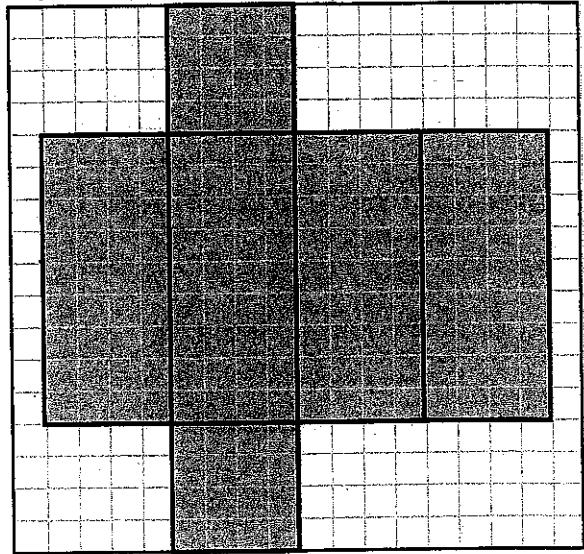

How are the two figures you just built alike?

---

---

---

---

How are the two figures you just built different?

## Talk About It

1. In the first activity, what two-dimensional figure forms the faces of the figure? How many faces are there? How many are congruent?

---

2. Identify the length, width, and height of the cube you formed in the first activity.

---

3. What do you notice about the length, width, and height of the cube?

---

4. **Processes & Practices**  **Identify Structure** In the second activity, what two-dimensional figures form the faces of the figure? How many faces are there? How many are congruent?

---

---

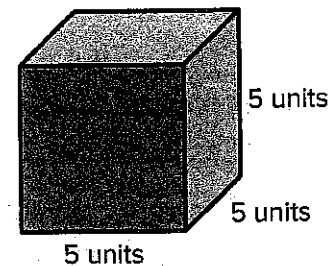

Name \_\_\_\_\_

## Practice It

For Exercises 5 and 6, refer to the grid at the right.

5. Copy the net onto grid paper. Cut out the net and fold along the lines to form a three-dimensional figure. What figure did you form?

6. What two-dimensional figure forms the faces of the figure?

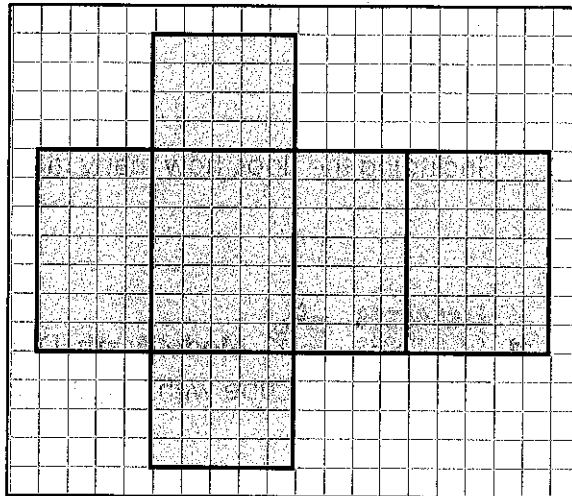

How many faces are there? \_\_\_\_\_ Describe the congruent faces.

For Exercises 7–9, refer to the grid at the right.

7. Copy the net onto grid paper. Cut out the net and fold along the lines to form a three-dimensional figure. What figure did you form?

8. What two-dimensional figure forms the faces of the figure?

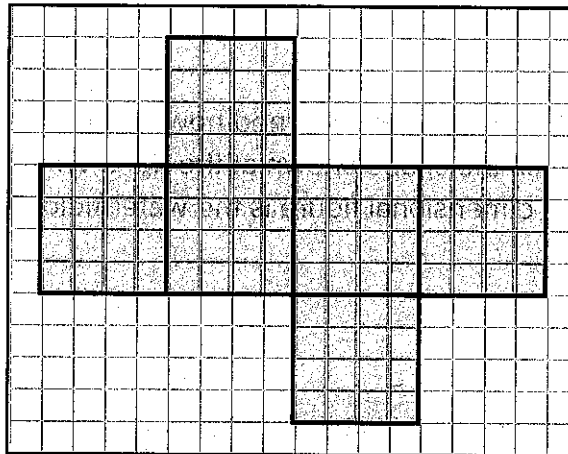

How many faces are there?

Describe the congruent faces.

9. Identify the length, width, and height of the figure you formed.



## Apply It

10. The rectangular prism-shaped building shown at the right was used for the 2008 Olympics in Beijing, China. What two-dimensional figures form the sides of the building?

Including the floor, how many faces are there?

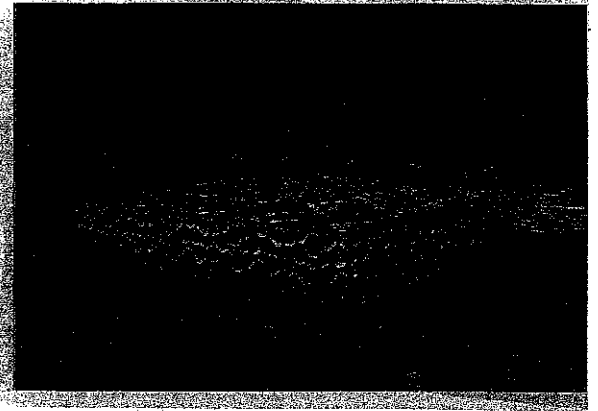

Processes & Practices



11. **Model Math** Draw two different nets that would fold to form a cube with length, width, and height each 4 units.

12. Farmers have learned how to grow watermelons in the shape shown at the right. What three-dimensional figure is the watermelon?

What happened to me?

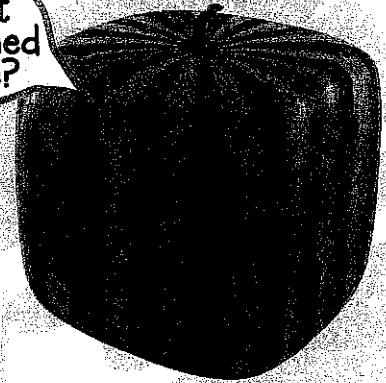

## Write About It

13. How are nets used to build three-dimensional figures?

---

---

---

Name \_\_\_\_\_

# Homework

## Lesson 6

### Hands On: Build Three-Dimensional Figures

## Homework Helper



Need help? [connectED.mcgraw-hill.com](http://connectED.mcgraw-hill.com)

The net shown was used to form the three-dimensional figure below.

The three-dimensional figure formed from the net is a rectangular prism.

The faces of the rectangular prism are rectangles.

The figure has 6 faces.

The four rectangles are congruent, and the two squares are congruent.

The figure formed has a length of 4 units, a width of 6 units, and a height of 6 units.

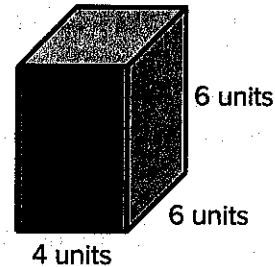
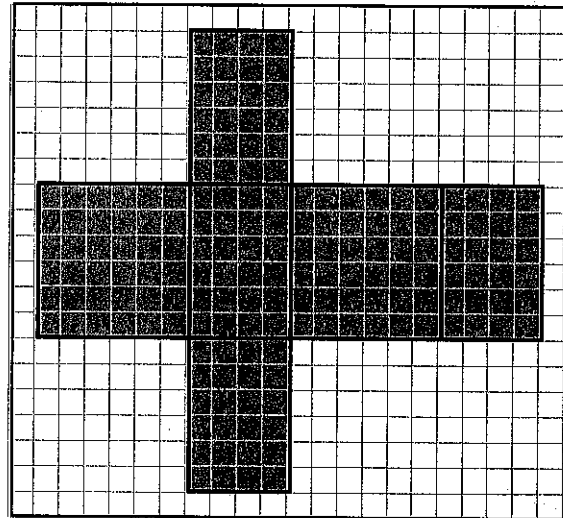

## Vocabulary Check



Fill in each blank with the correct word(s) to complete each sentence.

1. A three-dimensional figure has \_\_\_\_\_, width, and \_\_\_\_\_.
2. A net is a two-dimensional \_\_\_\_\_ of a three-dimensional figure.
3. A cube is a three-dimensional figure with six square faces that are \_\_\_\_\_.

# Practice

For Exercises 4–6, refer to the grid at the right.

4. What three-dimensional figure is formed using the net shown?

.....

5. What two-dimensional figure forms the sides of the figure?

.....

Describe the congruent faces.

.....

6. Identify the length, width, and height of the figure formed.

.....

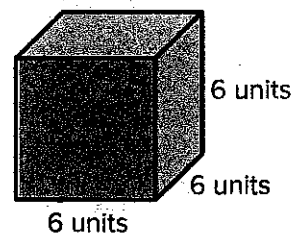
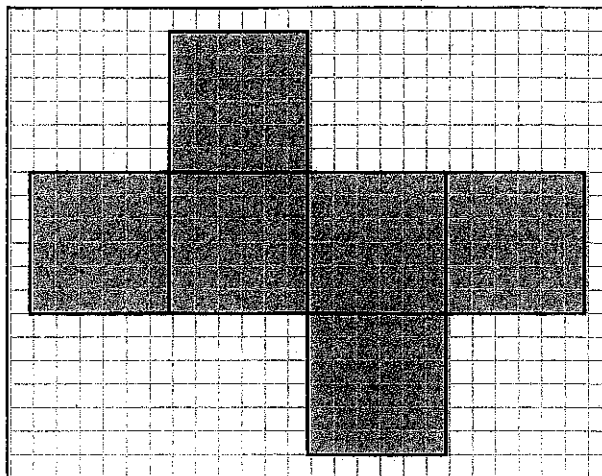

## Problem Solving

7. Rachel used a rectangular prism-shaped box to ship a package to her friend. What two-dimensional figure forms the faces of the box?

Including the bottom, how many faces are there?

Describe the faces.

8. Joseph is forming a three-dimensional figure using a net. The figure has six congruent square faces. What type of figure did he make?

Name \_\_\_\_\_

# Lesson 8 Hands On



## Use Models to Find Volume

### ESSENTIAL QUESTION ?

How does geometry help me solve problems in everyday life?

**Volume** is the amount of space inside a three-dimensional figure. Centimeter cubes can help you find the volume of a prism.

### Build It



Use centimeter cubes to build four different rectangular prisms. Complete the fourth and fifth columns of the table below for each prism.

Prism	Length (cm)	Width (cm)	Height (cm)	Number of Cubes	Volume (cubic cm)
A	1	2	1		
B	2	2	1		
C	3	2	2		
D	4	2	2		

A prism built from cubes has no gaps or overlaps.

A cube with a side length of one unit is called a **unit cube**.

A unit cube has a volume of 1 cubic unit, or  $1 \text{ unit}^3$ .

A **cubic unit** is a unit for measuring volume.



1 cubic unit



2 cubic units

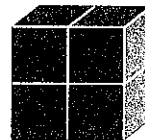

4 cubic units

So, if you use 12 centimeter cubes to build a rectangular prism, the prism has a

volume of \_\_\_\_\_ cubic centimeters, or \_\_\_\_\_  $\text{cm}^3$ .



## Try It

Use centimeter cubes to build the rectangular prism shown. Complete the table for each layer.

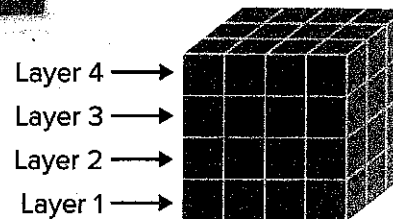

Layer	Length (cm)	Width (cm)	Height (cm)	Number of Cubes	Volume (cubic cm)
1					
2					
3					
4					

How many cubes were used to build the prism? \_\_\_\_\_

What is the volume? \_\_\_\_\_

## Talk About It

- Describe the relationship between the number of cubes needed to build a rectangular prism and its volume, in cubic units.

.....

.....

- Describe the pattern in the table between the length, width, height, and volume of each prism.

.....

.....

- Use  $l$  for length,  $w$  for width, and  $h$  for height to write a formula for the volume  $V$  of a rectangular prism.

.....

- Processes & Practices** **Use Math Tools** Use your formula to find the volume of the prism at the right in appropriate units. Verify your solution by counting the number of cubes.

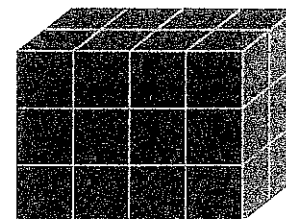

Name .....

# Practice It

**Processes & Practices** **5** Use Math Tools Use centimeter cubes to build the rectangular prism shown.

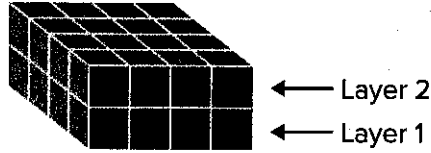

5. Complete the table below.

Layer	Length (cm)	Width (cm)	Height (cm)	Number of Cubes
1				
2				

6. How many cubes were used to build the prism? .....

What is the volume? .....  $\text{cm}^3$

Use centimeter cubes to build the rectangular prism shown.

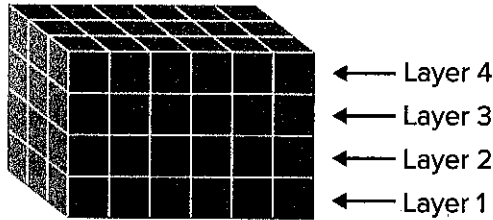

7. Complete the table below.

Layer	Length (cm)	Width (cm)	Height (cm)	Number of Cubes	Volume (cubic cm)
1					
2					
3					
4					

8. How many cubes were used to build the prism? .....

What is the volume? .....  $\text{cm}^3$



## Apply It

Use the prism shown for Exercises 9–11.

9. What shape is the base of the prism?

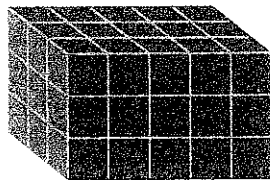

10. **Processes & Practices**  **Explain to a Friend** Explain to a friend how to find the area of the base of the prism.

11. Find the volume of the prism above by multiplying the area of the base by the height. Verify your solution by counting the number of centimeter cubes.

12. **Processes & Practices**  **Make Sense of Problems** Valerie knows that the volume of a prism is 36 cubic units. She knows that the length of the prism is 4 units and the width is 3 units. What is the height of the prism?

## Write About It

13. Describe a way to find the volume of a rectangular prism without using models.

Name \_\_\_\_\_

# Homework

## Lesson 8

### Hands On: Use Models to Find Volume

## Homework Helper



Need help? [connectED.mcgraw-hill.com](http://connectED.mcgraw-hill.com)

Centimeter cubes were used to build the rectangular prism shown. The table shows the number of cubes that were used to build each layer.

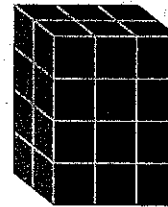

← Layer 4  
← Layer 3  
← Layer 2  
← Layer 1

Layer	Length (cm)	Width (cm)	Height (cm)	Number of Cubes	Volume (cubic cm)
1	3	2	1	6	6
2	3	2	1	6	6
3	3	2	1	6	6
4	3	2	1	6	6

So, 24 cubes were used to build the prism.

The volume of the prism is 24 cubic centimeters, or  $24 \text{ cm}^3$ .

## Vocabulary Check



Fill in each blank with the correct term or number to complete each sentence.

1. Volume is the amount of \_\_\_\_\_ inside a three-dimensional figure.
2. A cube with a side length of \_\_\_\_\_ unit is called a unit cube.
3. The volume of a rectangular prism can be found by multiplying the length by the \_\_\_\_\_ by the height.

# Practice

For Exercises 4–7, centimeter cubes were used to build the rectangular prism shown.

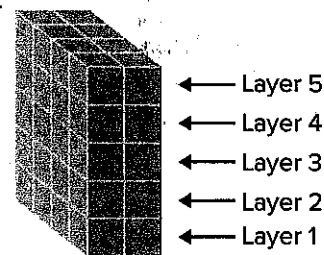

4. How many cubes were needed to build Layer 1?

5. Complete the table below.

Layer	Length (cm)	Width (cm)	Height (cm)	Number of Cubes	Volume (cubic cm)
1					
2					
3					
4					
5					

6. How many cubes were used to build the prism?

7. What is the volume of the prism?



## Problem Solving

**8. Processes & Practices** **Make Sense of Problems** Samir knows that the volume of a prism is 40 cubic units. He also knows that the width of the prism is 2 units and the height is 5 units. What is the length of the prism?

9. Centimeter cubes were used to build the prism. What is the volume of the prism?

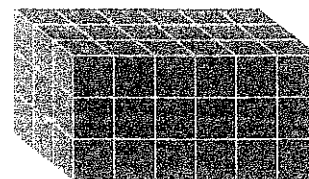

Name .....

# Lesson 9 Volume of Prisms

## ESSENTIAL QUESTION ?

How does geometry help me solve problems in everyday life?

**Volume** is the amount of space inside a three-dimensional figure. You can use either formula below to find the volume of a prism.

$$V = \ell \times w \times h \quad V = \text{volume}, \ell = \text{length}, w = \text{width}, \text{ and } h = \text{height}$$

$$B = \ell w$$

$$V = B \times h \quad V = \text{volume}, B = \text{area of the base}, \text{ and } h = \text{height}$$

Common units of volume are cubic inches, cubic feet, cubic yards, cubic centimeters, and cubic meters.



## Math in My World



### Example 1

On his family vacation to the beach, Armando filled a cooler with water and snacks. Find the volume of the cooler.

One Way Use  $V = \ell \times w \times h$ .

$$V = \ell \times w \times h$$

$$V = \dots \times \dots \times \dots$$

$$V = \dots$$

Another Way Use  $V = B \times h$ .

$$V = B \times h$$

$$V = \dots \times \dots$$

$$V = \dots$$

Volume formula

$$\ell = 30, w = 15, h = 20$$

Multiply.

Volume formula

$$B = 30 \times 15, h = 20$$

Multiply.

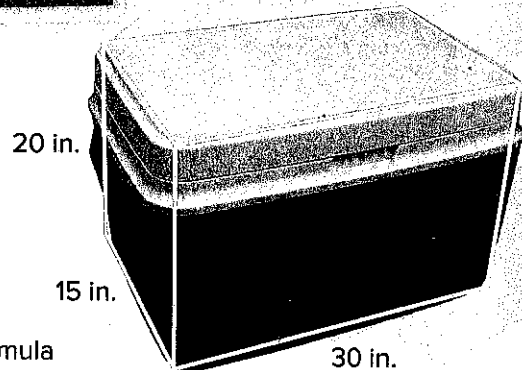

The volume of the cooler is ..... cubic inches.

Remember that the Associative Property of Multiplication tells you that the way in which factors are grouped does not change the product. You can group the factors to make the multiplication easier.

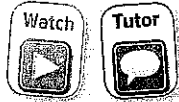

### Example 2

Find the volume of the prism.

$$V = \ell \times w \times h$$

Volume formula

$$V = 17 \times 7 \times 9$$

$$V = \dots \times (\dots \times \dots)$$
 Associative Property

$$V = \dots \times \dots$$
 Multiply.

$$V = \dots$$
 Multiply.

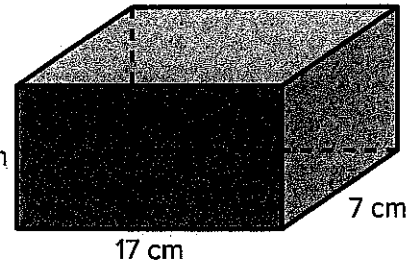

The volume of the prism is  $\dots$   $\text{cm}^3$ .

## Guided Practice

Find the volume of each prism.

1.

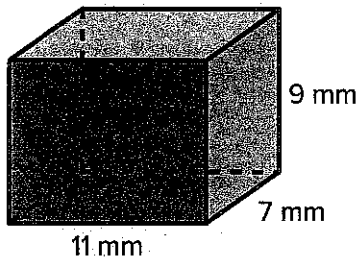

$$V = \ell \times w \times h$$

$$V = \dots \times \dots \times \dots$$

$$V = \dots \text{ mm}^3$$

2.

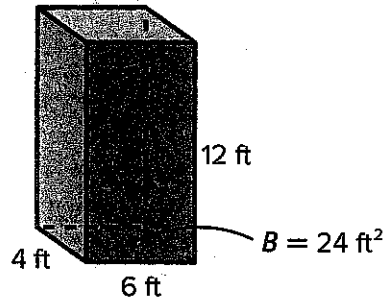

$$V = B \times h$$

$$V = \dots \times \dots$$

$$V = \dots \text{ ft}^3$$

### TALK MATH

If you know the area of the base of a rectangular prism and the prism's height, which formula would you use? Why?

Name .....

# Independent Practice

**Processes & Practices**



**Use Symbols** Find the volume of each prism. Use the formula  $V = \ell \times w \times h$  or  $V = B \times h$ .

3.

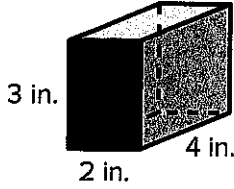

$V =$  .....

4.

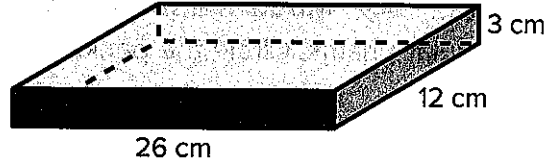

$V =$  .....

5.

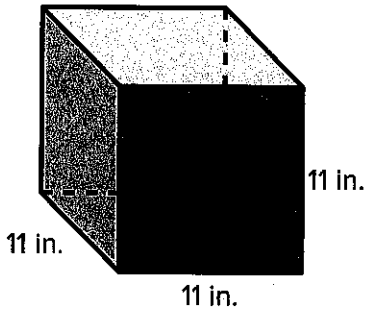

$V =$  .....

6.

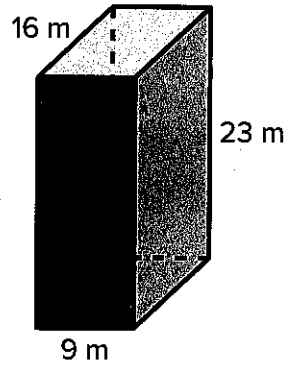

$V =$  .....

7.

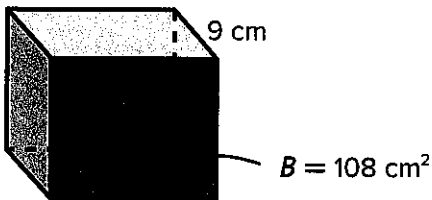

$V =$  .....

8.

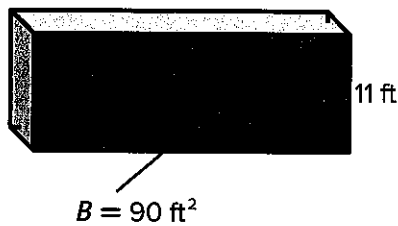

$V =$  .....







## Problem Solving

9. Find the volume of the Frog Queen building in Graz, Austria. The building is 18 meters long, 17 meters tall, and 18 meters wide.

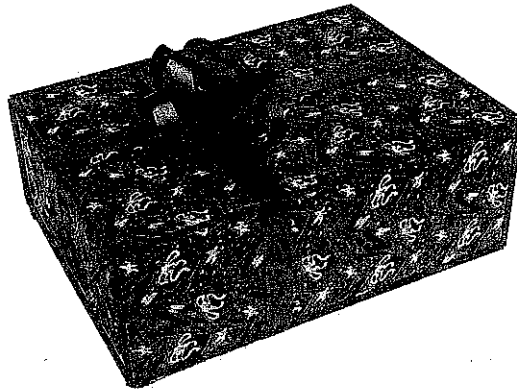
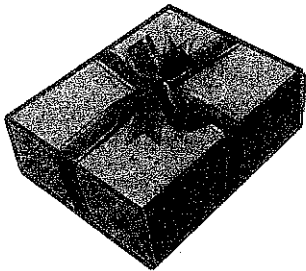
10. **Processes & Practices**  **Model Math** Two packages are in the shape of rectangular prisms. Circle the package that has the smaller volume.



## Brain Builders

11. **Processes & Practices**  **Use Number Sense** Explain how the Associative Property can be used to mentally find the volume of the prism shown. Then state the volume.

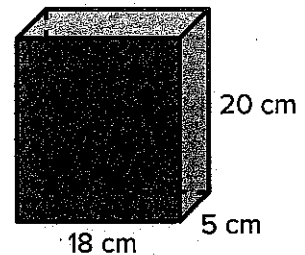

12.  **Building on the Essential Question** How do I find the volume of rectangular prisms?

Name \_\_\_\_\_

# Homework

## Lesson 9

### Volume of Prisms

## Homework Helper



Need help? [connectED.mcgraw-hill.com](http://connectED.mcgraw-hill.com)

Find the volume of the prism.

$$V = \ell \times w \times h$$

Volume formula

$$V = 13 \times 6 \times 8$$

$$\ell = 13, w = 6, h = 8$$

$$V = 624$$

Multiply.

The volume of the prism is  $624 \text{ cm}^3$ .

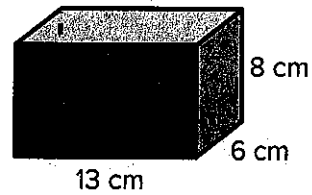

## Practice

Find the volume of each prism.

1.

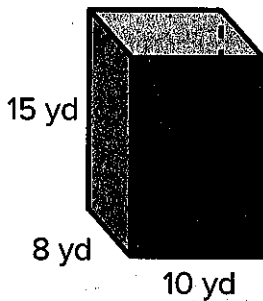

$$V = \underline{\hspace{2cm}}$$

2.

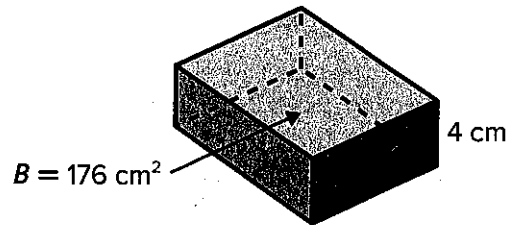

$$V = \underline{\hspace{2cm}}$$

## Vocabulary Check



Fill in the blank with the correct term or number to complete the sentence.

3. Volume is measured in \_\_\_\_\_ units.



## Problem Solving

4. The Donaldsons' swimming pool measures 15 meters long, 8 meters wide, and 3 meters deep. How many cubic meters of water will the pool hold?
5. The hotel that the Hutching family is staying at on vacation is shaped like a rectangular prism. It is 234 feet long, 158 feet wide, and 37 feet tall. What is the volume of the hotel?

### Brain Builders

6. Jena has a small jewelry box in the shape of a cube with side lengths of 2 inches. How much greater is the volume of her large jewelry box with dimensions 7 inches, 5 inches, and 4 inches?

7. **Processes & Practices**  **Model Math** Describe the dimensions of two different prisms that each have a volume of 2,400 cubic centimeters. Then draw each prism.

Is it possible for the prisms to have two of the same dimensions?

8. **Test Practice** What is the volume of the prism formed by the luggage bag?

- (A) 6,000 in<sup>3</sup>  
(B) 6,600 in<sup>3</sup>  
(C) 7,200 in<sup>3</sup>  
(D) 7,400 in<sup>3</sup>

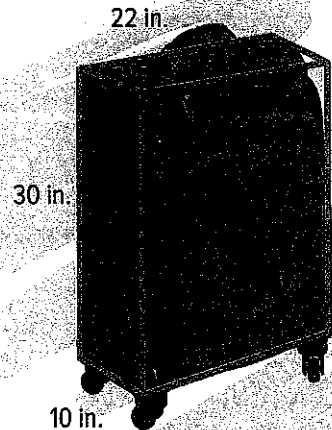

Name \_\_\_\_\_

# Lesson 10 Hands On Build Composite Figures

**ESSENTIAL QUESTION**   
How does geometry help  
me solve problems in  
everyday life?

A **composite figure** is made up of two or more three-dimensional figures.

## Build It



A composite figure is shown below. Use centimeter cubes to build the figure.

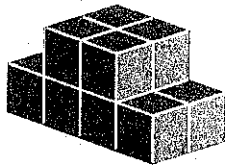

1

Count the number of cubes needed to make the base layer.

How many cubes did you use? \_\_\_\_\_

2

Count the number of cubes needed to make the top layer.

How many cubes did you use? \_\_\_\_\_

+

3

Add the number of cubes for the base and the top.

## Talk About It

1. How many cubes did it take to build the figure?
2. What is the volume of the composite figure?

\_\_\_\_\_ cubic centimeters

## Try It

Separate the composite figure into two rectangular prisms. Then find the volume of each prism.



1 Find the volume of the top prism.

$$V = \ell \times w \times h$$

$$V = \text{ } \times \text{ } \times \text{ }$$

$$V = \text{ }$$

The volume of the top prism is \_\_\_\_\_ cubic centimeters.



2 Find the volume of the bottom prism.

$$V = \ell \times w \times h$$

$$V = \text{ } \times \text{ } \times \text{ }$$

$$V = \text{ }$$

The volume of the bottom prism is \_\_\_\_\_ cubic centimeters.



3 Add the volumes to find the volume of the composite figure.

$$\text{ } + \text{ } = \text{ }$$

So, the volume of the composite figure is \_\_\_\_\_ cubic centimeters.

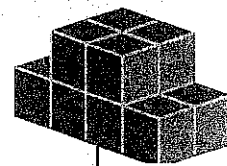

## Talk About It

3. Explain how you can use addition to find the volume of a composite figure.

---



---

4. **Processes & Practices**



**Make Sense of Problems** Explain how you would find the volume of the composite figure shown.

---



---

5. What is the volume of the figure in Exercise 4?

\_\_\_\_\_ cubic centimeters

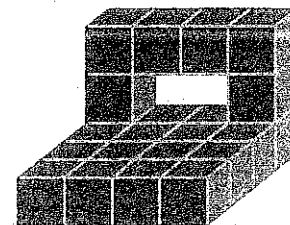

Name .....

## Practice It

Use the model at the right to build the composite figure using centimeter cubes.

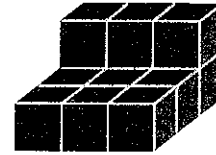

6. Separate the figure into prisms. Make a drawing of each prism used to build the composite figure.

7. How many cubes did it take to build the figure?

8. What is the volume of this figure?

..... cubic centimeters

Use the model at the right to build the composite figure using centimeter cubes.

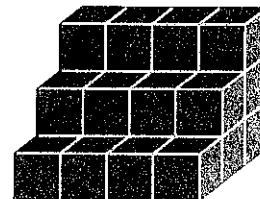

9. Separate the figure into prisms. Make a drawing of each prism used to build the composite figure.

10. How many cubes did it take to build the figure?

11. What is the volume of this figure?

..... cubic centimeters



# Apply It

Tanela arranged centimeter cubes into the composite figure shown. Use the composite figure for Exercises 12 and 13.

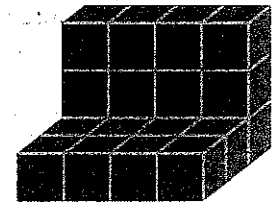

- 12. Processes & Practices**  **Model Math** Separate the figure into prisms. Make a drawing of each prism used to build the composite figure.

**13.** What is the volume of the composite figure? Check your answer by building a model and counting the number of cubes. \_\_\_\_\_ cubic centimeters

**14.** Circle the composite figure that has a volume of 24 cubic centimeters.

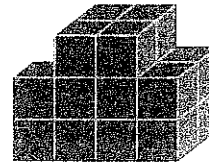
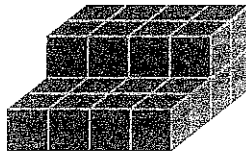
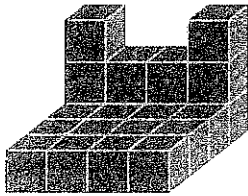

- 15. Processes & Practices**  **Make Sense of Problems** Explain how to use the formula of a rectangular prism to find the volume of a composite figure that is composed of rectangular prisms.

---



---

## Write About It

**16.** How can you use models to find the volume of composite figures?

---



---



---

Name \_\_\_\_\_

# Homework

## Lesson 10

### Hands On: Build Composite Figures

## Homework Helper



Need help? [connectED.mcgraw-hill.com](http://connectED.mcgraw-hill.com)

A composite figure is shown at the right. Centimeter cubes were used to build the figure. Find the volume.

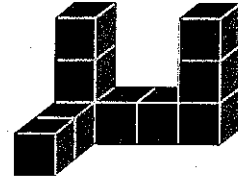

1 Six cubes were used to make the base layer.

2 Four cubes were used to make the two top layers.

3 Add the number of cubes for the base and the top.  
 $6 + 4 = 10$

So, a total of 10 cubes were used to build the figure.  
The volume is 10 cubic centimeters.

## Practice

Refer to the composite figure at the right.

1. How many cubes are needed to build the bottom layer?

\_\_\_\_\_

2. How many cubes are needed to build the top two layers?

\_\_\_\_\_

3. Use addition to add the bottom and top layers.

\_\_\_\_\_

4. What is the volume of the composite figure?

\_\_\_\_\_ cubic centimeters

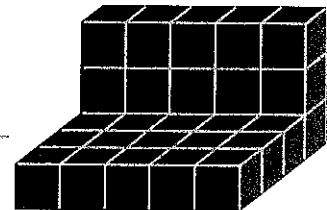





# Problem Solving

Jared built the composite figure at the right using centimeter cubes.

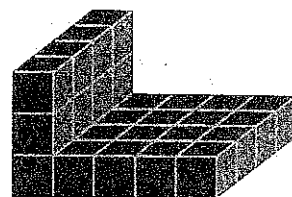

- Separate the figure into prisms. Make a drawing of each prism used to build the composite figure.

- How many cubes did it take Jared to build the figure?

- What is the volume of this figure? \_\_\_\_\_ cubic centimeters

**Processes & Practices**



**Find the Error** Gabriele built a composite figure using 12 cubes for the bottom layer and 10 cubes for the top layer. She said that the volume of the composite figure was  $12 \times 10$ , or 120 cubic centimeters. Find and correct her error.

## Vocabulary Check



Fill in the blank with the correct term or number to complete the sentence.

- A composite figure is made up of two or more \_\_\_\_\_ figures.

- The composite figure was built using centimeter cubes. What is the volume of the composite figure shown?

$V =$  \_\_\_\_\_ cubic centimeters

